

Corrugated Metering System

THE HARRIS & BRUNO CORRUGATED METERING SYSTEM IS DESIGNED SPECIFICALLY FOR CORRUGATED FLEXO PRINTERS AND INCORPORATES MANY FEATURES NOT FOUND IN COMPETITIVE SYSTEMS

Harris & Bruno International is a complete solution provider for ink delivery, metering and wash-up systems for corrugated post print flexo stations. Engineered to retrofit existing rubber roll metering configurations, H&B's complete lineup of chambered doctor blade systems, coupled with our innovative pumping technology, make for a seamless integration into your existing press. We can bring your print quality to the next level.

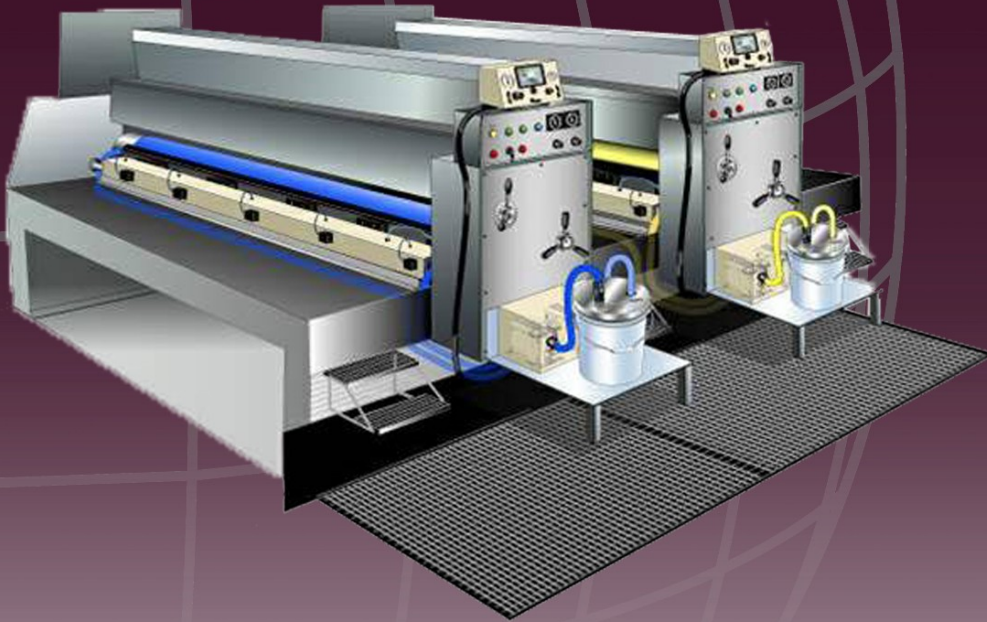

Features & Benefits:

- Automated PLC with touch screen controls
- Advanced "Smart Pump" technology
- Constructed of the highest quality materials
- HydroComp air-over-oil chamber loading
- Fully integrable into OEM press console
- Color to color wash-up in minutes
- Improved print quality
- Reduced ink usage
- World wide support & service

THE MOST ADVANCED CHAMBERED DOCTOR BLADE SYSTEM FOR CORRUGATED FLEXO PRINT STATIONS

- For more than 60 years, Harris & Bruno has supplied printers and converters with quality equipment built on the philosophy of honesty, integrity and trust
- All equipment is manufactured at a dedicated factory for cost effectiveness
- H&B uses the latest technology, combined with superior service and support

Contact us today ... to learn more about how the H&B Corrugated Metering System can revolutionize your print quality!

(916) 781-7676
www.harris-bruno.com



United States: 8555 Washington Blvd. • Roseville, CA 95678 • Phone 916-781-7676 • Fax 916-781-3645 • www.harris-bruno.com
Europe: Auf der Hohe 15 • 73529 Schwäbisch Gmünd • Germany • Phone +49-7171-94704-0 • Fax +49-7171-94704-20 • www.harris-bruno.de
Japan: 2-8-26-201 Ushikubo Higashi • Tsuzuki-ward • Yokohama-city • Kanagawa-pref. 224-0014 • Phone +81-(0)45-264-7555
Regional Offices Worldwide

Features & Benefits of the H&B Corrugated Metering System

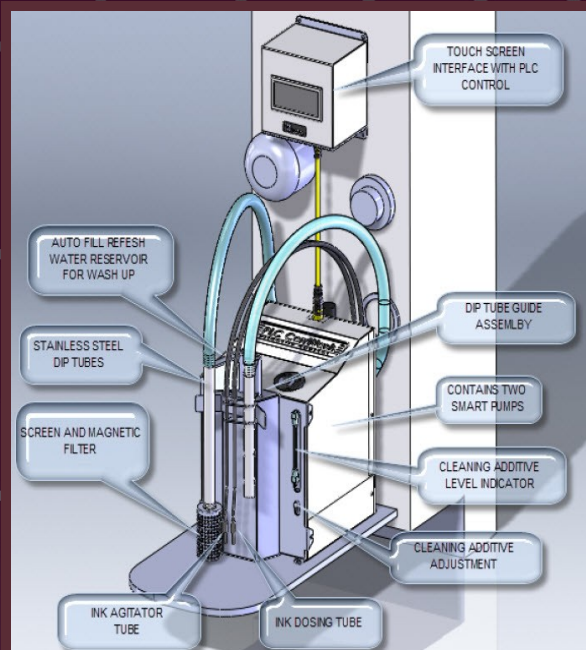

CP2

CP2 Pumping System

The H&B CP2 pumping system incorporates Smart Pump technology to partner the most reliable pump on the market with a pumping system specifically engineered for corrugated print stations.

- Touch screen/PLC control and operator prompting of all inking, optional viscosity control, and wash-up functions
- Dual pumping system provides balance between ink supply & return, keeping chamber in non-pressurized state
- Automated viscosity control option doses and mixes extender into ink
- Purge mode removes any residual wash fluid from inking system
- Soap injection aids in wash-ups
- Delivers superior cleaning results with minimal effort or complexity

HiFlow™ Chamber

- High flow rate chamber design reduces micro bubble formation
- Porting delivers ink into one end of chamber and returns it from the other
- Promotes efficient replenishment of anilox cells with less aeration of ink/coating
- Small cross section requires less ink/coating to charge system and has reduced sealing area
- Allows for increased press speeds
- Significantly reduces foaming, ghosting and starvation
- Results in quicker wash-ups and reduced end seal leakage

HiFlow Chamber

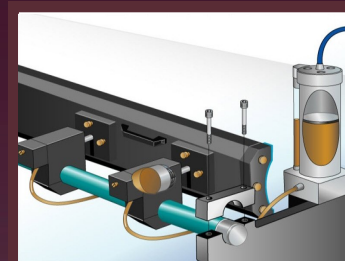
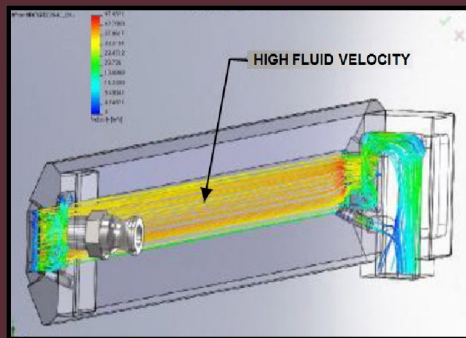

HydroComp

HydroComp™ Blade Loading

- Uses multiple air-over-oil cylinders to apply blade pressure uniformly
- Combines rigidity of mechanical loading with automatic compensation for blade wear
- Loaded on linear plane so blade angle and pressure are held constant through blade life

Optional Viscosity Control

- Unique and innovative way to monitor, control & dose for fluid viscosity
- Neatly incorporated into pumping system, sensors are placed inside pumps
- PLC controlled continuous feedback loop checks viscosity & doses ink or coating reducers in order to maintain pre-set viscosity target
- Allows for clean, practical way to monitor & control viscosity while avoiding messy configuration of parts & hoses typical of other viscosity control devices

Contact us today ... to learn more about how the H&B Corrugated Metering System can revolutionize your print quality!

(916) 781-7676

www.harris-bruno.com



United States: 8555 Washington Blvd. • Roseville, CA 95678 • Phone 916-781-7676 • Fax 916-781-3645 • www.harris-bruno.com
 Europe: Auf der Hohe 15 • 73529 Schwäbisch Gmünd • Germany • Phone +49-7171-94704-0 • Fax +49-7171-94704-20 • www.harris-bruno.de
 Japan: 2-8-26-201 Ushikubo Higashi • Tsuzuki-ward • Yokohama-city • Kanagawa-pref. 224-0014 • Phone +81-(0)45-264-7555
 Regional Offices Worldwide